

LESSON PLANS FOR TEAM TEACHING DEMONSTRATION WITH RICK WELSH

Dear Teaching Partner,

Thank you for participating in this phase of training. This packet will guide you as you submit a lesson plan for **the lesson that you and I will teach together**. I will be developing the training around that lesson plan. **Do not submit a lesson plan for the observation day**. Be sure to fill out the form on the next page as I will need that information to prepare the training.

I look forward to working in your classroom with you and your students. Please keep in mind that the purpose of this exercise is to demonstrate the process of adapting a traditional lesson plan in order to 1) create active roles for both professionals in the team teaching partnership and 2) create opportunities for a wider range of students to experience success.

Please prepare a lesson plan that reflects as much whole group instruction as possible. It is my job to provide the modifications. It is your responsibility to determine what is to be taught and to provide a general framework for how the lesson would normally be conducted. With that in mind, please do not try to create the "world's best lesson plan." If you do, you will create unnecessary work for yourself and you may experience resistance to the modifications that will be suggested.

Nametags for students: Please prepare name tags, (2.5"x3.5" adhesive type). Use a black magic marker to print the first name of each student in large bold print. Please bring the name tags to the planning session. We will code them during the planning session.

Grouping of students: Please sort your class into thirds, based on learning style. Then, **prior to my arrival**, create groups of 3 with one student from each learning style in each group. (See graphic)

Learning style 1. Students who need to physically interact with concepts in order to understand them. (Kinesthetic)

Learning style 2. Students who tend to understand what you say, the first time you say it. (Linguistic)

Learning style 3. Students who need to see a model in order for them to understand concepts. (Spatial)

A SILK Group in action

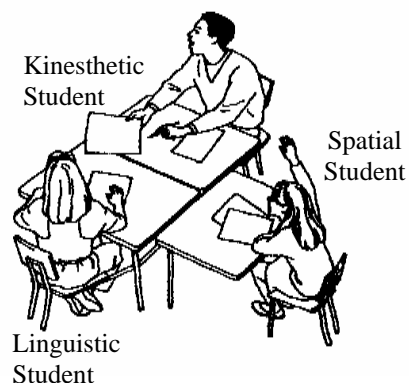

General overview of our co-teaching lesson

1. You and I meet to discuss the upcoming lesson and teaming strategies. All other team members observe. (60 minutes)
2. You and I team teach the lesson in your classroom with your students. All other team members observe (45 to 90 minutes)
3. You and I meet with the other team members to discuss the effects of the teaming on student outcomes during the team teaching lesson. (30 to 45 minutes)

Please fill out the form on the next page and attach it to your lesson plan. You may use your own lesson plan format **if it provides all of the information that I am requesting**.

Thank you, Rick Welsh, Speech-Language Pathologist
Educational Specialist, Team Teaching and Adapting Instruction for Inclusive Classrooms
1-919-499-6695 (telephone) rickwelsh@aol.com (e-mail) 1-708-570-1326 (fax)

Section A: General information

1. Your name:
2. Your school:
3. Your room number:
4. School telephone:
5. After hours telephone, (in case I need additional information prior to the training):
6. Your home E-mail (or fax)
7. Grade level we will teach together:
8. Subject we will teach together:
9. The date of our team teaching lesson:
10. Starting time of our team teaching teaching:
11. The projected length of the lesson, (in minutes):
12. Number of students in the classroom:
13. Number of EC/Special Education Students in the classroom:

Section B: Specific information about the lesson

1. What is the content area of the lesson?

2. What are the objectives/learner outcomes for this lesson?

3. How would you normally teach this lesson? (attach separate sheets if needed)

Section C: Please send the following along with your lesson plans:

- All worksheets that go along with the lesson. (Please fill in the answers)- -if possible e-mail them to me at rickwelsh@aol.com
- A copy of the notes that students will be expected to take-if possible e-mail them to me at rickwelsh@aol.com
- All other materials, that students will read or work with (textbooks*, novels*, articles, poems, , vocabulary lists math problems etc.)
- *Note- Middle and High school- Please submit novels, short stories & chapters of textbooks 1 week prior to lesson

Section D: Bring to the planning session:

Nametags for all students, (2.5"x3.5") Print first names only as large as possible in black marker. We will color code them to conform to learning style.

Writing board/ projection screen

Overhead projector

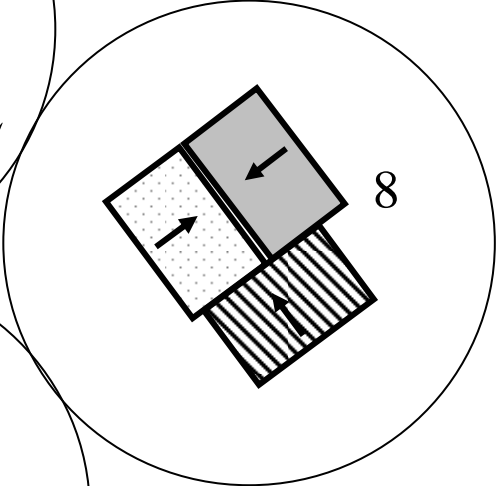
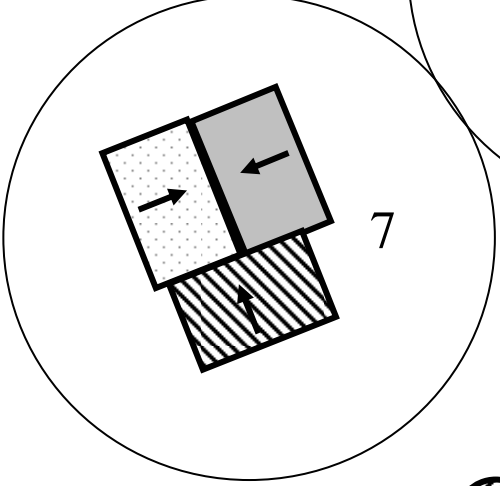
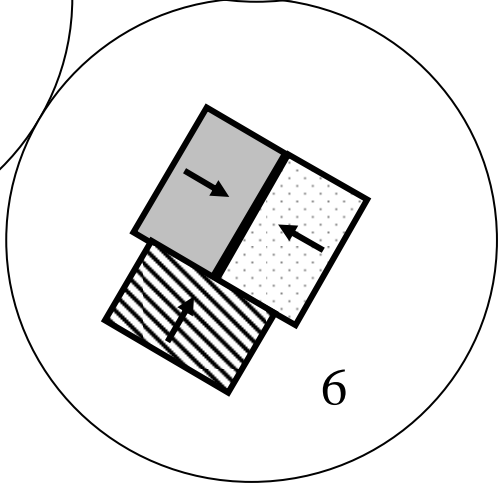
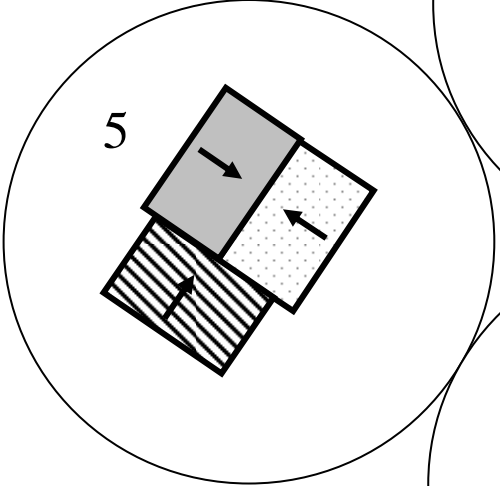
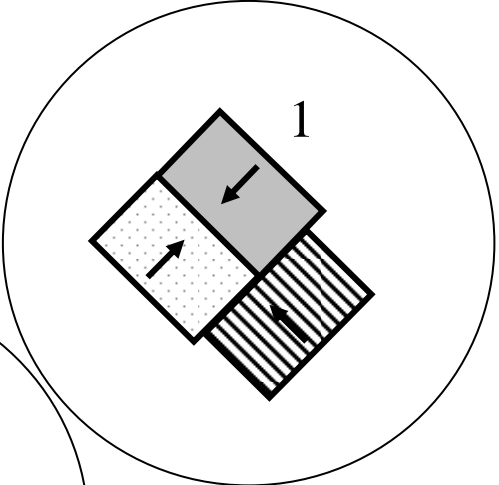
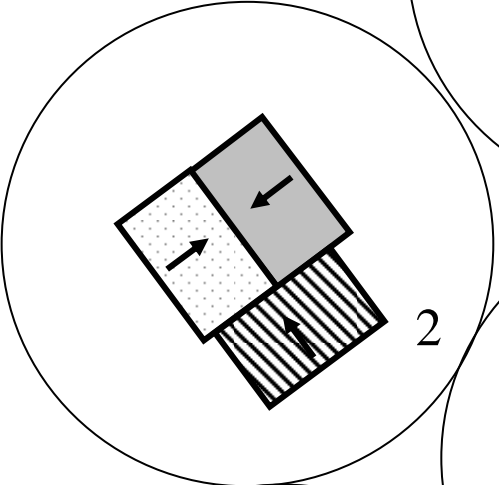
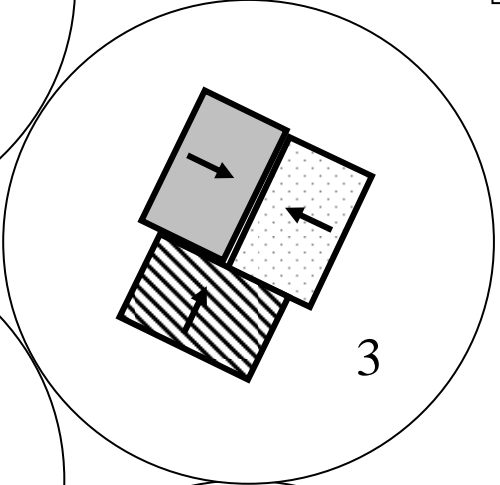
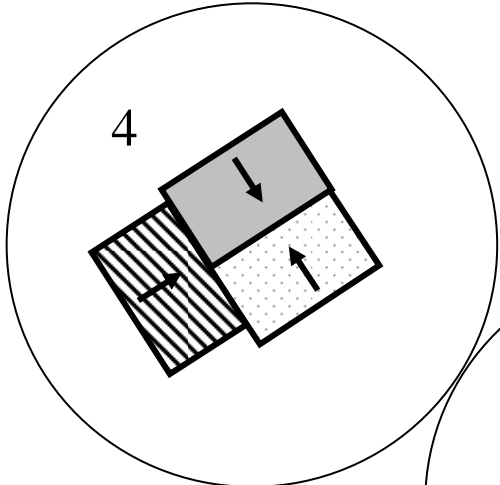

Kinesthetic



Linguistic



Spatial